

Installation Guide

iClock TFT Serial Access Control Station

About this Guide

- The S880 TFT Access Control Station User guide is designed to provide information to install the S880 TFT serial Access Control Station, for operation and configuration, please refer to the corresponding user's manual.
- Not all function these guides introduce available in combination, all is option.
- About your machine function, please consult our company technical personnel or the sales personnel.

Contents

1. Before Installing	1
1.1 Notice about installing	1
2. System Configuration	4
2.1 The illustration of system construction	4
2.2 The sketch map of communication	5
3. Installation	6
3.1 Fix Mounting Plate	6
3.2 Connect with peripheral equipment	7
3.2.1 Door sensor connection	9
3.2.2 Exit-button connection	10
3.2.3 Alarm connection	10
3.2.4 Door lock connection	12
3.2.5 Ethernet connection	17
3.2.6 RS232 connection	19
3.2.7 RS485 connection	20
3.2.8 Wiegand output connection	21
3.2.9 Connect with external Weigend reader	22
3.2.10 Power connection	23
3.3 Fastening fingerprint machine	25
4. Test and examine after installation	26
5. Others	27
5.1 Reset	27
5.2 Anti-dismantle button	28
5.3 Using U flash disk	28
5.4 Built-in EM card reader (Optional)	28
5.5 Built-in MIFARE card reader (Optional)	29
5.6 Cable doorbell (Optional)	29

1.Before Installing

1.1 Notice about installing

TFT screen Fingerprint Machine is a mass-produced product. It strictly follows to the criteria of manufacture and inspection of China, U.S.A, and EU. This file contains important information. It is better for you to read it carefully prior to use. If you ignore it, the incorrect installation may cause the unit damage. Although we could do our best to offer you service, the neglect to the file could cause unwanted cost for you.

1. Before installation, please make sure the power is cut off, because it is very dangerous if the power is on. The short-circuit of power cable may cause the core board damage.

2. All exposed part of connection wire end can not be exceeded 5mm to prevent the bared wire accidental connection which leads to machine break down. And using different colour cable to connect is Recommendation.

3. In the place where the static is strong or in winter, please connect the grounding firstly, in order to prevent the instant mass static damage the machine.

4. Connect power supply with device in the last for the wiring connection. If you find any unusual thing occur, please firstly cut off the power, then go to examine. Keep in mind: wiring operation under power on will lead to machine sudden damage; we are not liable for damages

and trouble due to such operation.

5. The height to mount device is about 1.4-1.5 meter

After installation, please take off protection film on the fingerprint sensor to get best recognize result.

6. After installation finish, when go to test the exit-door button, please keep a personal in the outside, because sometimes the accidental issue can bring on you are not able to go outside.

7. Our equipment offer an automatically function, please after the installing finish. Run the auto-test function to confirm the installation finish.

In order to guarantee machine run for long time, we set an auto-sleep and wake up function in the exit factory, please carefully examine this function normally setting before using.

8. We recommend using above the 12V/3A direct-current supply for ZK software's access control device, electricity lock better to powered by 12VDC, and no more than 1.5 A electric current. At this time, the electric current of supply should be above 1A than lock power. If the parameter of lock power surpasses this scope, please connect technical personnel. If the power had not met above requests, it possibly causes to be unable normally to drive the electricity lock, even damage the device.

9. Before device to be connected please read and always follow "Quick connect Guide" closely. Because the wrong wiring will cause the core block and sensor to burn out, insult in device to break down, at this cause ZK Software is not liable for any damages and trouble.

10. If the space between power adapters and device is too long, please do not use the twisted-pair or other type ferrules for the power wire. When the power wire is choused, you should consider attenuation of voltage which has passed long distance transfer.

11. Please use specialized RS485 cable and the RS232/485 converter with power to hookup the network, the bus structure apply to connect

with each device. When a long cable is used to transfer signal, it is need to connect a matching resistance to receiver, and its value is 120Ω .

12. Other not details items; please see also the user handbook, the operating instructions and the appendix and so on

2. System Configuration

2.1 The illustration of system construction

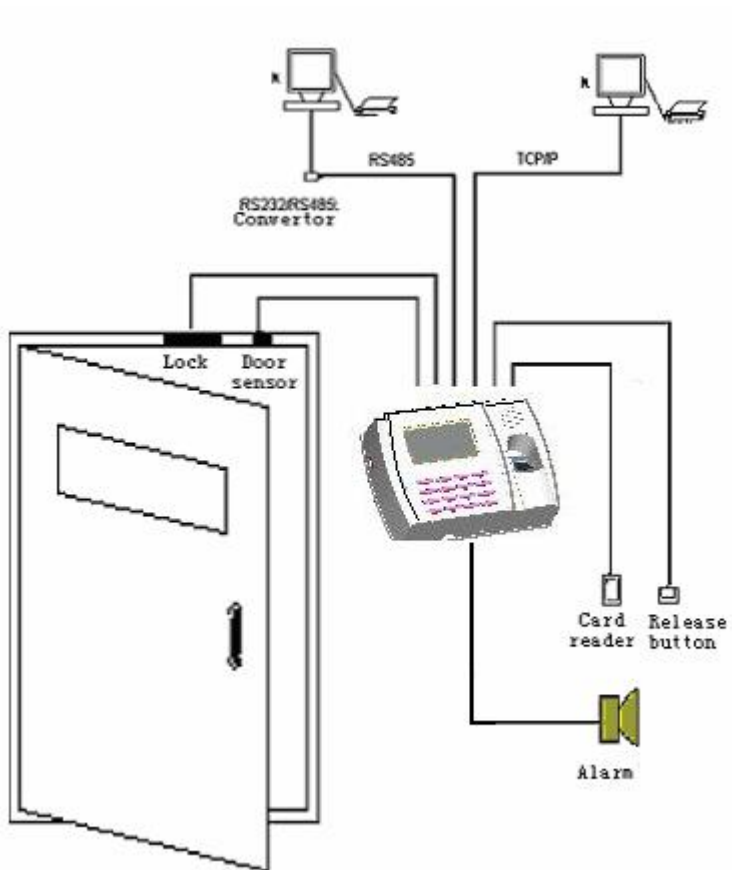

2.2 The sketch map of communication

Fingerprint machine directly connects with PC through RS232 or TCP/IP

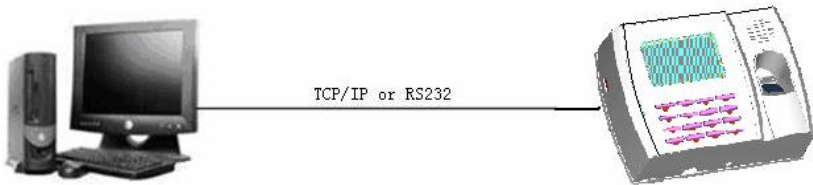

Fingerprint machine connects with PC through RS485 network

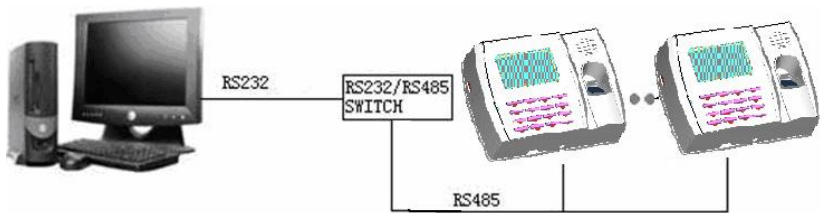

Fingerprint machine connects with PC through TCP/IP network

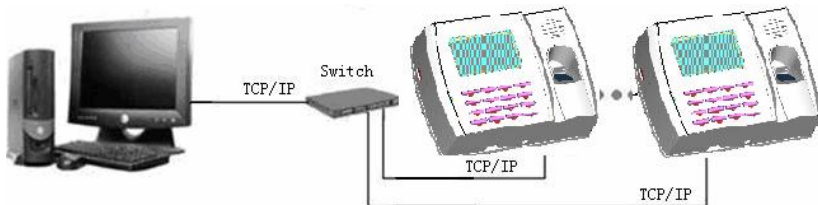

3. Installation

3.1 Fix Mounting Plate

- ① Take out a fingerprint machine, dismantle the screw between machine body and mounting plate until it is out, see figure (1).
- ② Carefully take up the bottom of mounting plate, see figure (2), push it up, see figure (3), then take away the mounting plate.
- ③ Determine the position of mounting plate on the wall. The fingerprint machine should be mounted on the external wall of the door approximately 1400mm from the ground to the unit bottom. After the position is determined, you could drill a hole (18mm*20mm) for cable out, see below figure shadowed part.
- ④ Make the hole of mounting plate meet the drilled hole on the wall, Use the screw to fix it on the wall, (for the details please see following figure a, b, c, d)
- ⑤ After installation, please make sure the mounting plate is reliable, fasten, not loosed.

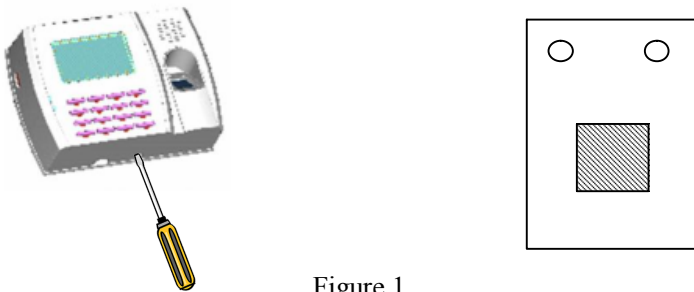

Figure 1

3.2 Connect with peripheral equipment

Caution: Do not to connect peripheral equipment before the power of the device is cut down, otherwise it is possible to damage the device badly.

Please follow instruction to connect peripheral equipment

- ① Door sensor connection
- ② Exit-button connection
- ③ Alarm connection
- ④ Door lock connection
- ⑤ Ethernet connection
- ⑥ RS232 connection
- ⑦ RS485 connection
- ⑧ Wiegand output connection
- ⑨ Power connection

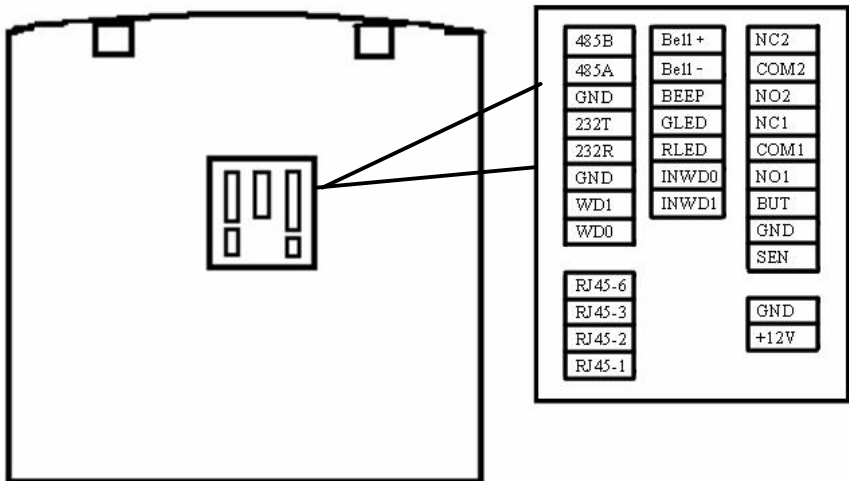

Table 1 the definition of the Pin of TFT screen Fingerprint Machine connector

J12, Pin connector on middle below of the rear panel (from the top)			
1st	485B	Connect to RS485B	Tie up together
2nd	485A	Connect to RS485A	
3rd	GND	Connect to RS232 GND	
4th	TXD	Connect to RS232 TXD	Tie up together
5th	RXD	Connect to RS232 RXD	
6th	GND	Connect to Weigand out GND	
7th	WD1	Connect to Weigand out WD1	Tie up together
8th	WD0	Connect to Weigand out WD0	

J2, 4Pin connector on middle above of the rear panel (from the top)			
1st	RJ45-6	Connect to RJ45 plug wiring 6	Tie up together
2nd	RJ45-3	Connect to RJ45 plug wiring 3	
3rd	RJ45-2	Connect to RJ45 plug wiring 2	
4th	RJ45-1	Connect to RJ45 plug wiring 1	

J17, 7Pin connector on right side below of the rear panel (from the top)			
1st	Bell+	Connect to Cable Bell+	Tie up together
2nd	Bell-	Connect to Cable Bell-	
3rd	BEEP	Spare	
4th	GLLED	Spare	Tie up together
5th	RLED	Spare	
6th	INWD0	Connect to Weigand input	
7th	INWD1	Connect to Weigand input	

J 7, 9pin connector on left side above of the rear panel (from the top)			
1st	NC2	Connect to Alarm NC terminal	Tie up together
2nd	COM2	Connect to Alarm COM terminal	
3rd	NO2	Connect to Alarm NO terminal	
4th	NC1	Connect to Lock NC terminal	Tie up together
5th	COM1	Connect to Lock COM terminal	
6th	NO1	Connect to Lock NO terminal	
7th	Button	Connect to Release button	Tie up together
8th	GND	For Door sensor and release button	
9th	Sensor	Connect to Door sensor	

J1, 2Pin connector on left side below of the rear panel (from the top)			
1st	GND	Connect to Power GND	Tie up together
2nd	+12V	Connect to Power +12v	

3.2.1 Door sensor connection

The door sensor is used to detect the door open-close state , TFT screen Fingerprint Machine can monitor if the door has been unauthorized open through the door sensor, at this time it can output a alarm signal, moreover, TFT screen Fingerprint Machine can trigger prompt warning if after surpassing a timed period , the door still open.

3.2.2 Exit-button connection

The exit-button is installed for in-door operation. When switch the button to close, the door will open. The distance is approximately 1400mm from ground to exit-button bottom. Make sure that the exit-button position is to align correct, upright and the connection is accurate and reliable. (Unused exposed end of cable should be cut off, and use insulating tape to wrap it.) Pay attention to electromagnetic disturbance. (For example: The light switch, the computer and so on)

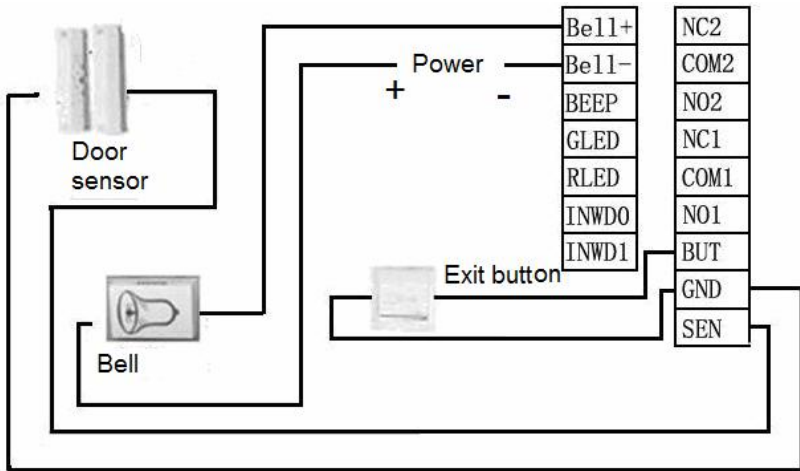

3.2.3 Alarm connection

TFT screen Fingerprint Machine alarm output is a switch signal, it is able to connect with simple alarm by serial circuit, it also apply to top grade alarm and monitor system as a trigger signal(this machine alarm

function only support 12 VDC Warner)

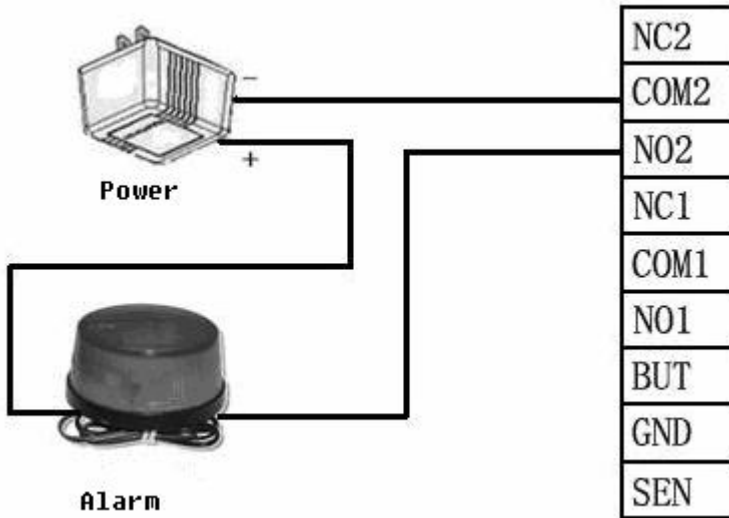

Connect the Normal Close Alarm

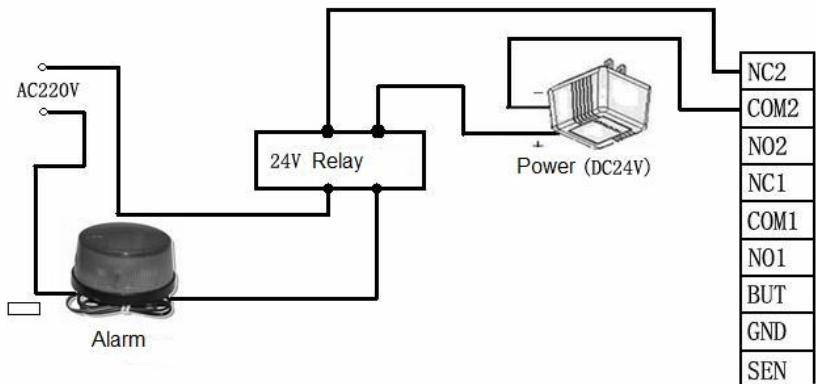

Connect the Normal Open alarm

3.2.4 Door lock connection

The way of installing door lock depends on the type of lock and local condition. Internal resistor, which comes from long distance transfer, should be taken into consideration when selecting the cable of electric power. The door lock should be installed reliable and stable. Ensure the wiring is correct. For the strike lock and electromagnetic lock, you should pay attention to positive and negative terminal connection. The unused bare end of wire should be cut off and use insulating tape to wrap it. The delay time of strike lock is adjustable according to different conditions.

Select electric lock : It is better to use **electric drop bolt** for the two-direction opening glass door (both open to inside or outside direction), for the single opening wood door in company internal , we recommend to use magnetic lock, the magnetic lock also be called as electric magnetic lock,. The magnetic lock is more reliable than the electric drop bolt, but the electric drop bolt is much safer than the magnetic lock. In the small living community, it is better to use electric drop bolt and magnetic force lock. The electric control lock gives out higher noise; the electric control lock is commonly used to building communication. Now there is a soundless electric control lock which is able to be applied. Please pay attention, the lock is made of iron and easy rust, so you must beware of not exposing it to water or harsh condition, there are some other electric locks available, we don't recommend you to use them.

Connect with electric lock

Input terminal of release door button (Button, GND) The input port of release door button accepts the signal which come from normally opened contact to indicate that somebody want to go out, the input equipment such as “ action detector”, “ press sensitivity floor board” or exit-door button all serve as source to send signal, if nobody send out request to want to go out, the input disconnection , if somebody want to go out, they trigger release door button, the circuit is closed. Produce state is changed, the controller responded to the request, unlock and permit door serve as passage mode.

Note: 1) the process of performance to unlock door is control by relay, when you install door lock, there are two thing you must think about, -- safety and security , in other words, do you want which result that is if lose control of this door, the door is still in safety—“lost control but safety” or if lose control of this door, the door still is security--- “ lost control but security”

2) When the Access Control System connected with Electric lock, to prevent the self-inductance EMF to affect the access control system, you need to parallel one FR107 diode (do not reverse the polarity) . Please use the equipped diode in the package.

“Lost control but safety” is that the power supply cut off (maybe the power supply is cut or the controller lose control of itself, the door will be open automatically, and permit everybody freely to pass in and out, the door is not ability to be closed until the system power on, these type of doors are installed in the protective area which ensure everybody is able to pass in and out. One representative application of “ lost control but safety” is to use electromagnetism lock, under normal power supply, the door is controlled by the controller, once the power supply break off,

the electromagnetism lock will lose magnetism and does not take effect, the door become a passage mode

“Lost control but security” is that the power supply cut off, the door will be locked automatically, do not permit external personal to come in, but permit internal personal go out, the door is not to be unlocked until the system power supply is in gear. Make sure that the door of “lost control but security” will be installed in the area, which needs to be protected through fair and foul. One representative application of “lost control but security” is to use electrical lock, if the power supply break off, the external personal is not able to open the door, but the internal person can open the by manual operation.

The working power of the fingerprint access control terminal is DC12V, and the working current is approximate 400mA. If the working power of the lock is DC12V while its working current is 1000mA much lower than the current of fingerprint machine’s power, it is allowed to fingerprint machine and lock work together by one power supply .

In the following three cases, we recommend that the fingerprint machine and the lock is powered separately. you can following picture3 and picture4.

- 1) The working voltage of the lock is DC12V, but the current is difference of the fingerprint machine and the lock doesn’t exceed 1A.
- 2) The lock voltage is not DC12V.
- 3) The distance between lock and fingerprint machine is too far.

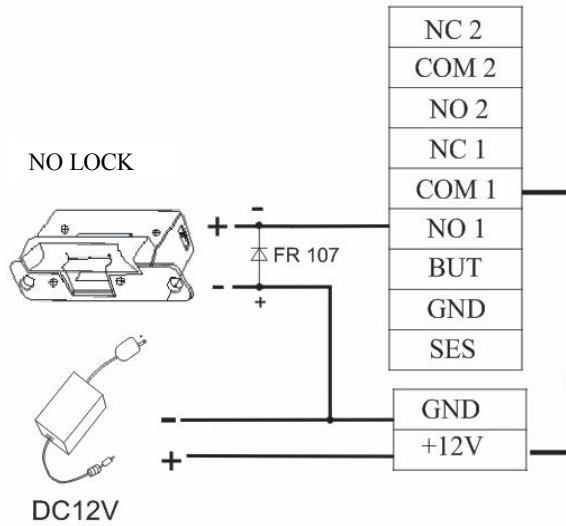

Picture1 Power by one supply

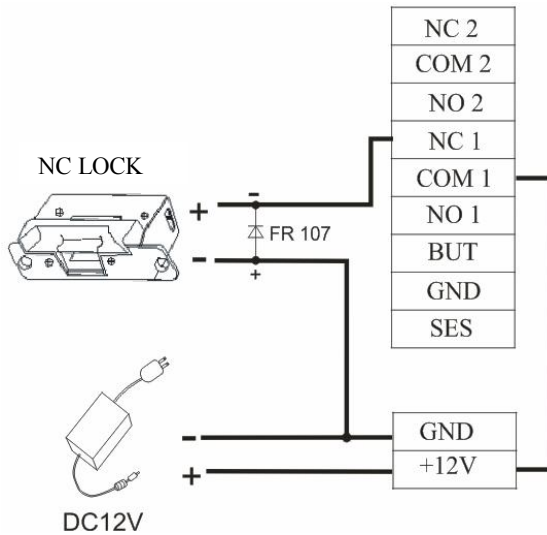

Picture2 power by one supply

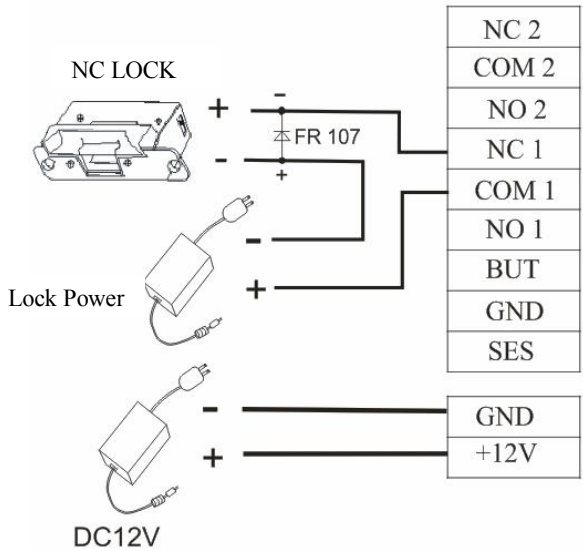

Picture3

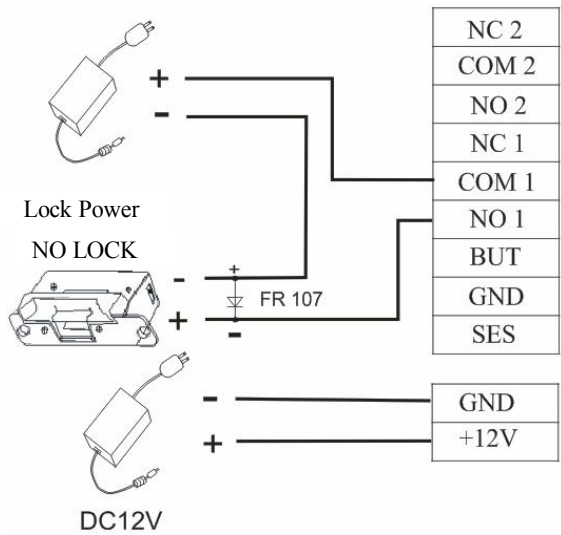

Picture4

3.2.5 Ethernet connection

The TFT screen Fingerprint Machine provide two ways connect Ethernet

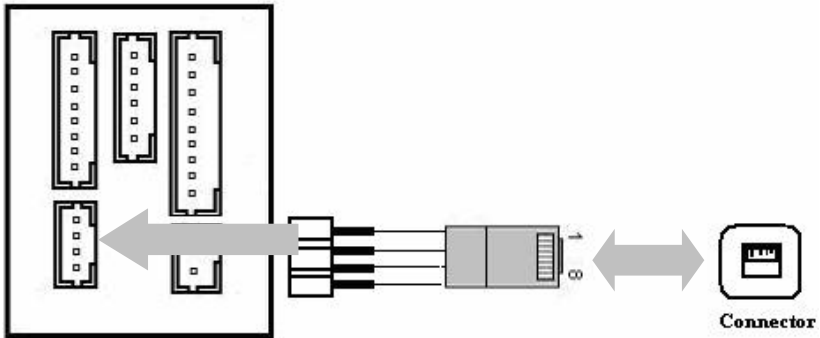

1).TFT screen Fingerprint Machine connects with PC through cross cable



2) TFT screen Fingerprint Machine connects with PC through network and HUB to create a local network

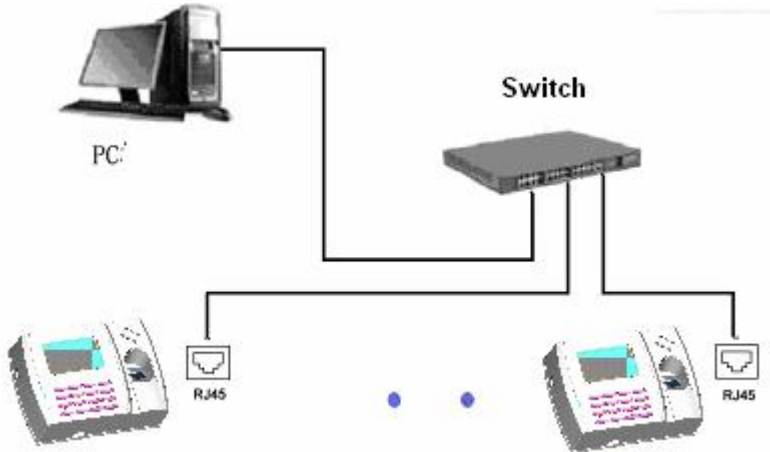

- 3) RJ45 plug wiring diagrams for Ethernet
 a) RJ45 plug standard

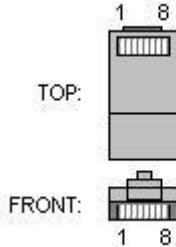

- b) Ethernet 10/100Base—T Crossover Cable
 mostly apply to HUB and Switch, or directly connect two Ethernet terminals(not through HUB), fully support 10Base-T and 100Base-TX.

<i>Plug1</i>	<i>Pin</i>		<i>Pin</i>	<i>Plug 2</i>
TX+	1	<—>	3	RX+
TX-	2	<—>	6	RX-
RX+	3	<—>	1	TX+
RX-	6	<—>	2	TX-

c) Ethernet 10/100Base-T Straight Thru Cable

Support 10Base-T and 100Base-TX, apply to connect with network card and HUB (or network outlet), sometime it is called (whips)”

<i>Wiring standard</i>	<i>Pin</i>	<i>Color</i>	<i>Pin</i>	<i>Wiring standard</i>
TX+	1	<— white orange	—> 1	TX+
TX-	2	<— Orange	—> 2	TX-
RX+	3	<— white green	—> 3	RX+
	4	<— Blue	—> 4	
	5	<— Blue white	—> 5	
RX-	6	<— Green	—> 6	RX-
	7	<— White brown	—> 7	
	8	<— Brown	—> 8	

3.2.6 RS232 connection

The definition of PC connection with fingerprint machine

PC Serial Port	Fingerprint machine serial port(J12)
Pin2-Rxd	Pin4-Txd
Pin3-Txd	Pin5-Rxd
Pin5-Gnd	Pin3-Gnd

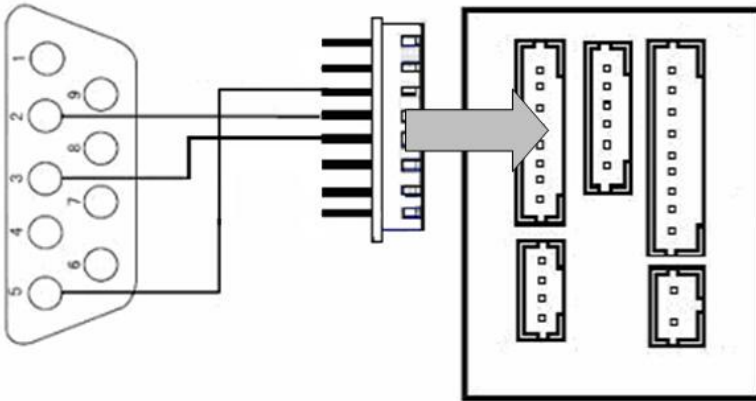

3.2.7 RS485 connection

RS-485 systems using a bus structure configuration connect the driver to the receiver. The transmission line is made by a group of pair-twisted cable. Each transmitted signal has a pair of conductors consisting of inverted and non-inverted signal lines. The inverted line is generally indicated by the index "A" or "-", with the non-inverted line designated as "B" or "+". The receiver simply evaluates the difference between the two lines, so that common mode noise on the transmission line will not result in a falsifying of the actual signal, however, on the line may be produced a difference mode disturbing. In order to eliminate this disturbance, traditional RS485 networks require a 12Ω terminal resistor to be installed at the end of the bus cables based on the physical layout of the pair-twisted cables. In the normal condition the resistor is not installed, only if the bus is extended to over 100 meters, the termination must be connected with a terminal resistor.

The define of terminal connection

Terminal(J12)	Function
Pin1-485B (White)	RS-485 communication -
Pin2-485A (Green)	RS-485 communication +

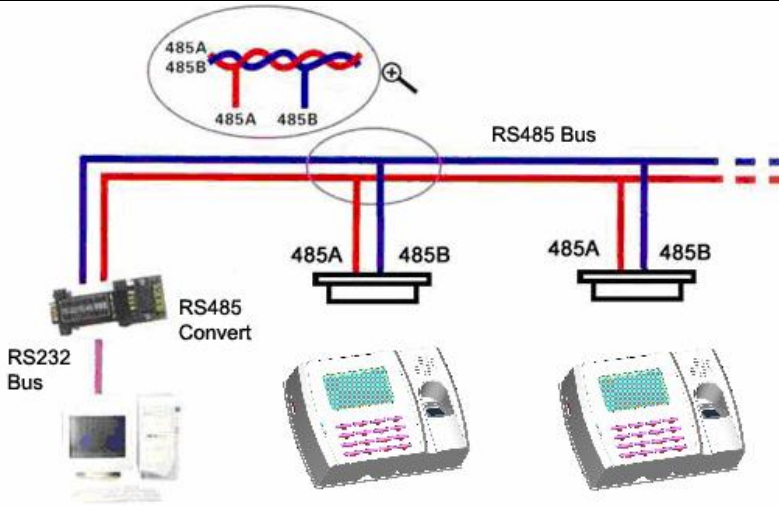

3.2.8 Wiegand output connection

TFT screen Fingerprint Machine provides standard Wiegand 26 output, which can be connected to most of access controllers, like the way of connecting with a ID reader or password keyboard. The distance from the controller to device can not be more than 15 meter (if the signal must be transferred much further or there is a strong interference around, please adopt a wiegand signal amplifier)

Note: no matter the device is powered by access controller or not, the

ground ports of them have to be properly together to ensure the weigand transfer reliable

Terminal(J12)	Function
Pin6- GND (Black)	Ground
Pin7-WD1 (White)	Output wiegand data 1 signal
Pin8- WD0 (Green)	Output wiegand data 0 signal

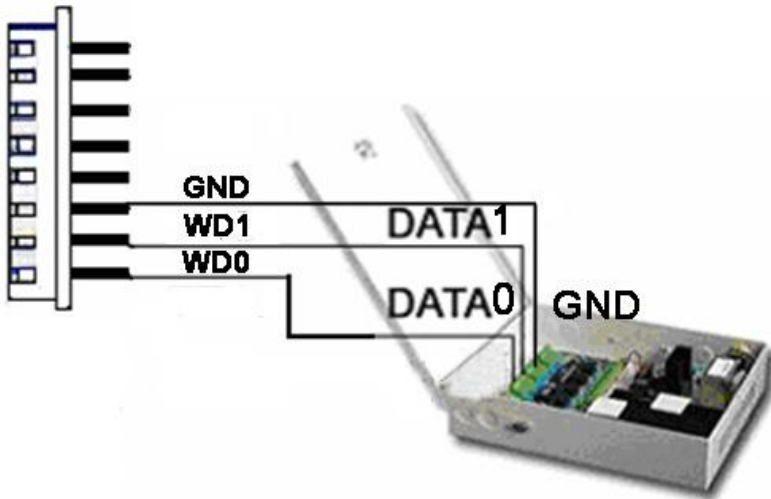

3.2.9 Connect with external Weigend reader

Access control device whit the Weigand input function is able to connect with card reader, which is located in outdoor or indoor, control the door by the controller together, the cable which between access controller and external card reader is no more than 90 meter.

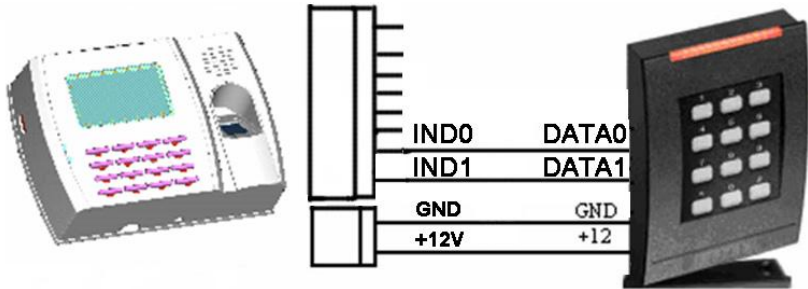

3.2.10 Power connection

This device is powered by 12VDC. Its current is approximately 50mA in the ready work status and 400mA in the work status. The power is conducted along with the terminal; you can use the 12V-4A supply adapter which is provided along with the device. The detail about connection is as follow.

Terminal(J1)	Function
Pin1- GND (Black)	Power negative
Pin2- PWR (Red)	Power positive

The following figure is an example which takes a provided power adapter to connect to TFT screen Fingerprint Machine:

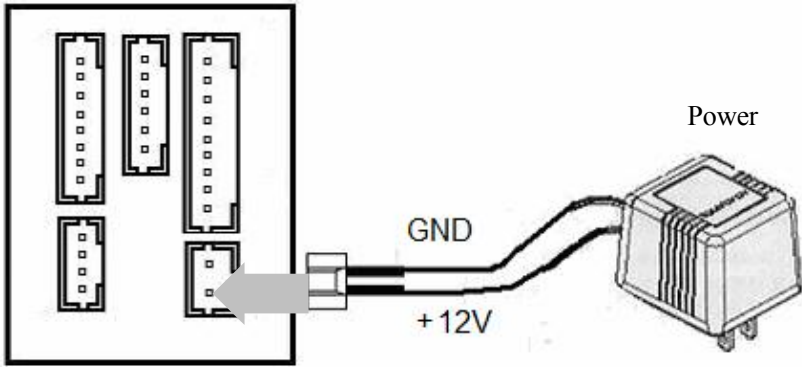

3.3 Fastening fingerprint machine

- ① Confirm all connection plugs correctly.
- ② Align back iron-plate of fingerprint machine body to mounting plate properly, and push it up, then push device backward.
- ③ Turn and tie up the screw bottom.

After finishing installation, make ensure the body of device is fixed tightly.

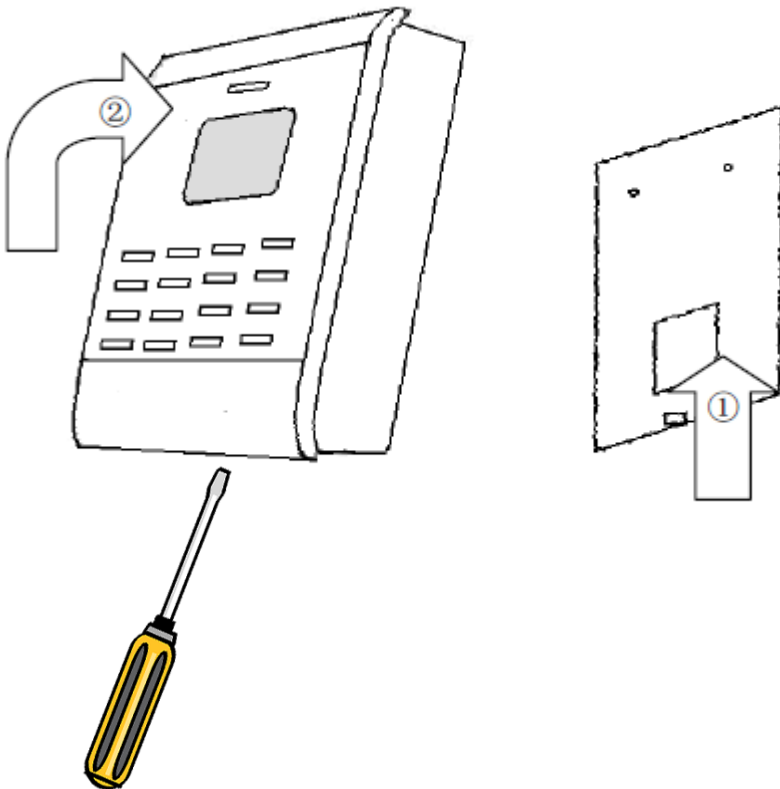

4. Test and examine after installation

After all system installation finished, make a test and examine prior to power on , inspect whether the lock driver is OK or not, for more details, please see “User Guide” and “Software Manual”

- ①the green LED begins to glitter after power up.
- ②enter menu→Option→ Auto-test.
- ③enter menu→User manage→User Enroll→Fingerprint Enroll, Enroll a fingerprint, and use the fingerprint to test access control system and door lock..
- ④if there is no any problem. Please delete this enrolled fingerprint.

5. Others

5.1 Reset

Due to operation error or other accident, which leads the machine not to work, you can restart machine through reset key.

- ①take a small tool which diameter is no more than 2mm.
- ②find reset mark of “reset” on the left small hole on the bottom or beside of device, see following figure.
- ③Use the tool plug into the hole refer to the picture on right , then plug out. The machine is able to restart.

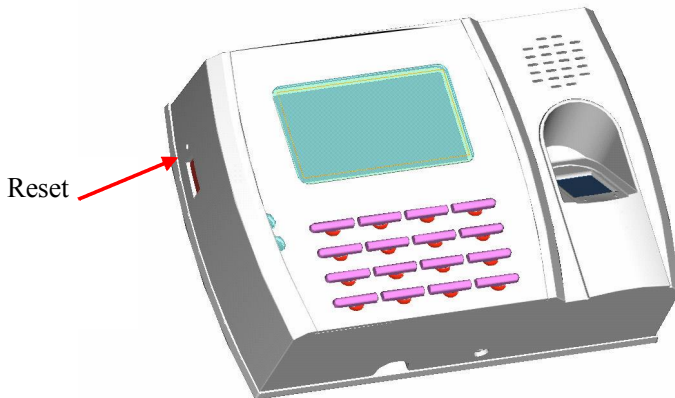

5.2 Anti-dismantle button

Anti-dismantle button is on middle of device, whose function is realized by back-cover pressing the anti-dismantle button. When the device is being dismantled, it will send a alarm signal through the terminal, more detail please see this handbook 3.2.3.

5.3 Using U flash disk

- ①there is a mini-port of USB.
- ②USB can be used to upload and download data by U disk, can be connected with U.are.U fingerprint sensor as an external fingerprint sensor.

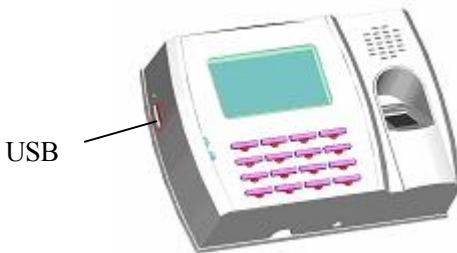

5.4 Built-in EM card reader (Optional)

Built-in a contact less EM card reader module, the distance of flashing card is 5-10 cm. it completely supports the thick card (1.88mm), middle card (1.05mm), and thin card (0.88mm), whose operating frequency is at

125 KHZ.

5.5 Built-in MIFARE card reader (Optional)

Contain a contact-less MIFARE card reader module , the distance to detect card is 5-10cm, it completely supports MIFARE cards that provide operating frequency 13.56MHZ, communication speed 106KBPS.

5.6 Cable doorbell (Optional)

There is a key which is remark as icon () on the keypad , this key is used for doorbell.

Put the doorbell in the proper place, press the doorbell key on the device, after the doorbell receive a signal, it will ring.

Note: Because the terminal and key our provided is used for cable doorbell, must join the power into the electric round.

